

DG8 / DG9



Manufactured in 304
Stainless Steel

MAGIDO DG8/DG9 models feature a large working sink, with a foot pedal activated flow-thru brush, lid closure, thermostat controlled heater, liquid level sensor, and tank drain.



DG8 / DG9

FEATURES

- Flow-thru hose and brush
- Thermostat controlled heater
- Liquid level sensor
- Removable work shelf
- Tank drain
- Hinged sink closure

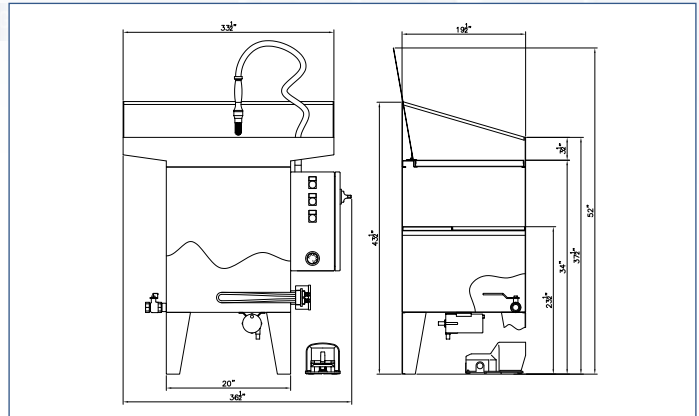

OPTIONS

- Cartridge filter
- Casters

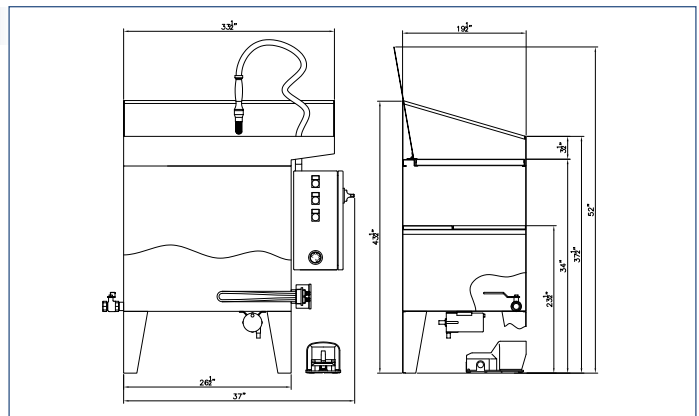

SPECIFICATIONS

DG8

DG9

		DG8	DG9
Working Area	Inches	33.5 x 19.5	33.5 x 19.5
Load Weight	Lbs.	300	300
Fluid Capacity	Gal.	26.5	34.5
Pump	GPH	238	238
Heater	kW	2	2
Voltage	Volts	115	115
Amperage	Amps	19	19
Operating Temperature	°F	113	113
Width	Inches	19.5	19.5
Length	Inches	37.5	37.5
Height	Inches	43.5	43.5
Shipping Dimensions	Inches	34 x 38 x 43	34 x 38 x 43
Net Weight	Lbs.	121	132

We reserve the right to modify without notice.

MAGIDO USA INC.