

# L7 / L10

Designed For Maintenance Parts Cleaning Applications



Manufactured in 304  
Stainless Steel

**The L-7 & L-10 models feature a vat-style design with flow-thru hose/brush assembly, flexible spigot, removable shelves, thermostat controlled heater, liquid level sensor, and tank drain.**



# L7 / L10

## FEATURES

## EIGENSCHAFTEN · CARACTERÍSTICAS

- Flow-Thru Pump and Brush
- Fluid Level Shut Off
- Thermostat Controlled Heater
- Removable Work Shelves
- Large Working Area

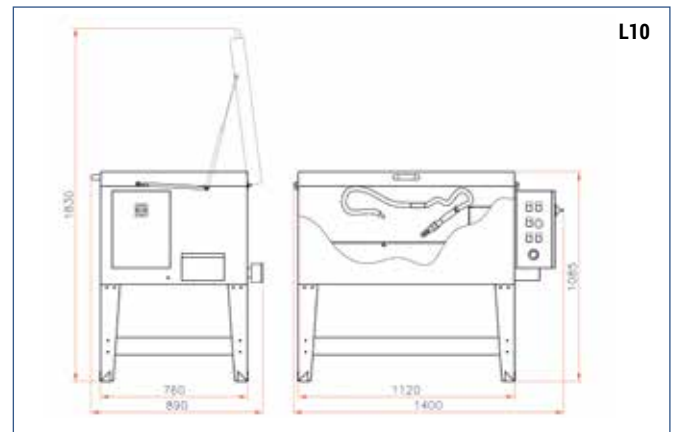
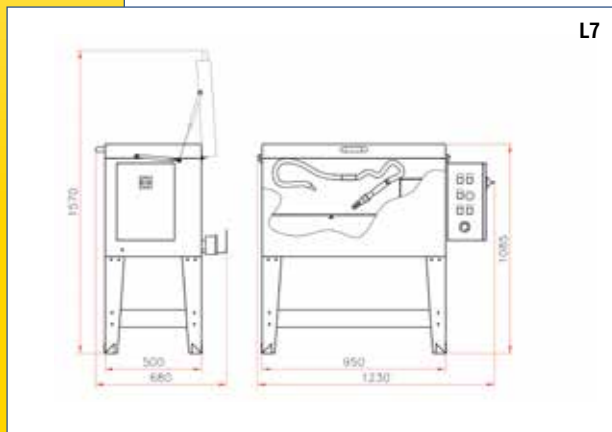

## SPECIFICATIONS

### L7

### L10

	Inches	<b>L19 x W27 ½</b>	<b>L29 ½ x W34</b>
Working Area			
Load Weight	Lbs	<b>300</b>	<b>300</b>
Fluid Capacity	Gal	<b>24</b>	<b>40</b>
Pump	GPM	<b>3.5</b>	<b>3.5</b>
Heater	kW	<b>2</b>	<b>2</b>
Voltage	Volts	<b>115</b>	<b>115</b>
Amperage	Amps	<b>19</b>	<b>19</b>
Operating Temperature	°F	<b>113</b>	<b>113</b>
Length	Inches	<b>27</b>	<b>35</b>
Width	Inches	<b>48 ½</b>	<b>55</b>
Height	Inches	<b>43</b>	<b>43</b>
Shipping Dimensions	Inches	<b>L26 x W48 x H30</b>	<b>L35 x W54 x H30</b>
Net Weight	Lbs	<b>155</b>	<b>210</b>

We reserve the right to modify without notice.

**MAGIDO USA INC.**

[sales@magidousa.com](mailto:sales@magidousa.com)  
[www.magidousa.com](http://www.magidousa.com)

P.O. BOX 2511 - 261 Tiger way - Peachtree City  
Georgia 30269 - USA - Ph. 844 4Magido